

Following the Trail of Destruction

By Brad Conatser, Doni Nastasi, and Kermit Phipps, EPRI PEAC Corp., Knoxville, Tenn.

Equipment with blown fuses, charred resistors, fried semiconductors, and vaporized circuit traces are on the workbenches of repair shops everywhere. Such obvious damage can be easily—perhaps too quickly—attributed to power surges.

When claims of equipment damage caused by faulty electricity cross the customer service desks of utilities, questions about the original cause border on the forensic. Was the damage due to old age? What about faulty components pushed over the edge by a common electrical disturbance? Was lightning to blame? These questions are never easy to answer, but definitive surge testing can reveal true stories about good components gone bad.

Utilities aren't the only companies interested in the cause-and-effect of equipment damage. Insurance companies, which shell out millions of dollars every year to owners of damaged equipment, are highly motivated to exploit standardized surge testing that

reveals original cause.

Consider data collected from a single regional insurance company. Between 1998 and 2001, one insurance company recorded 2,017 payments to policyholders with claims of damaged equipment. Of those 2,017 payments, 889—or 44%—were attributed to either lightning or surges, for an average of \$2,700 per claim. Over those four years, the company paid out more than \$2.4 million because of electrical excursions, an average of \$600,000 per year. Extrapolating this figure to the worldwide population of property-insurance companies yields the possibility of a significant amount of surge-inflicted equipment damage.

Developing test protocols, investi-

gative procedures, and a catalog of cause-and-effect associated with surge damage will require an outlay of time and resources that cannot be born by a single industry. A collaborative effort between utilities, insurance companies, manufacturers, and end users promises to shed some light on the destructive nature of power surges. The EPRI project, called *Analysis of Failure Mechanisms for Electrical and Electronic Equipment*, began this year with some exploratory testing in the laboratory.

Surge Testing Equipment

Surges can impinge upon equipment at the power port, communication port, or both. Because surge voltage can be coupled from the power port to a communication port, power quality investigators are generally interested in both ports. Surge testing the power port of equipment requires a surge generator capable of simulating the types of surges that impinge upon equipment

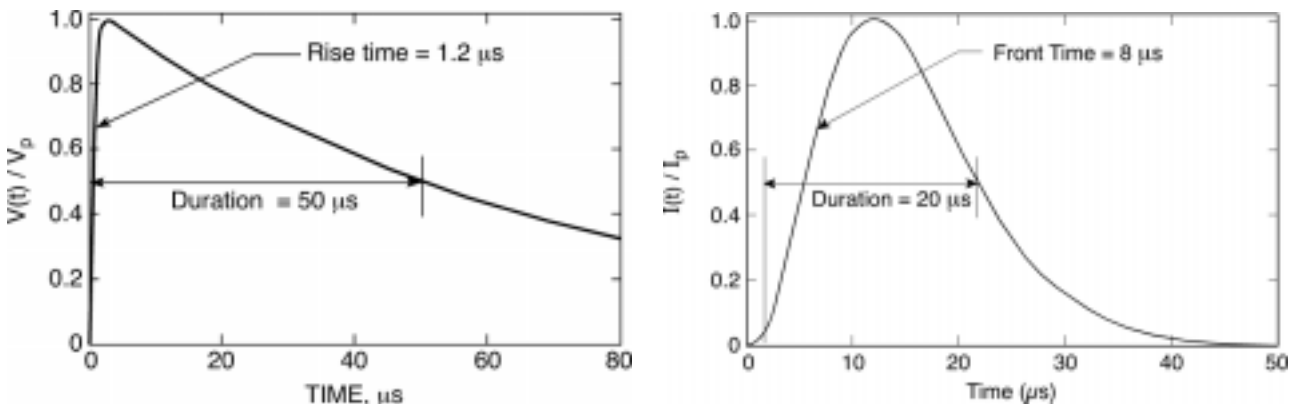
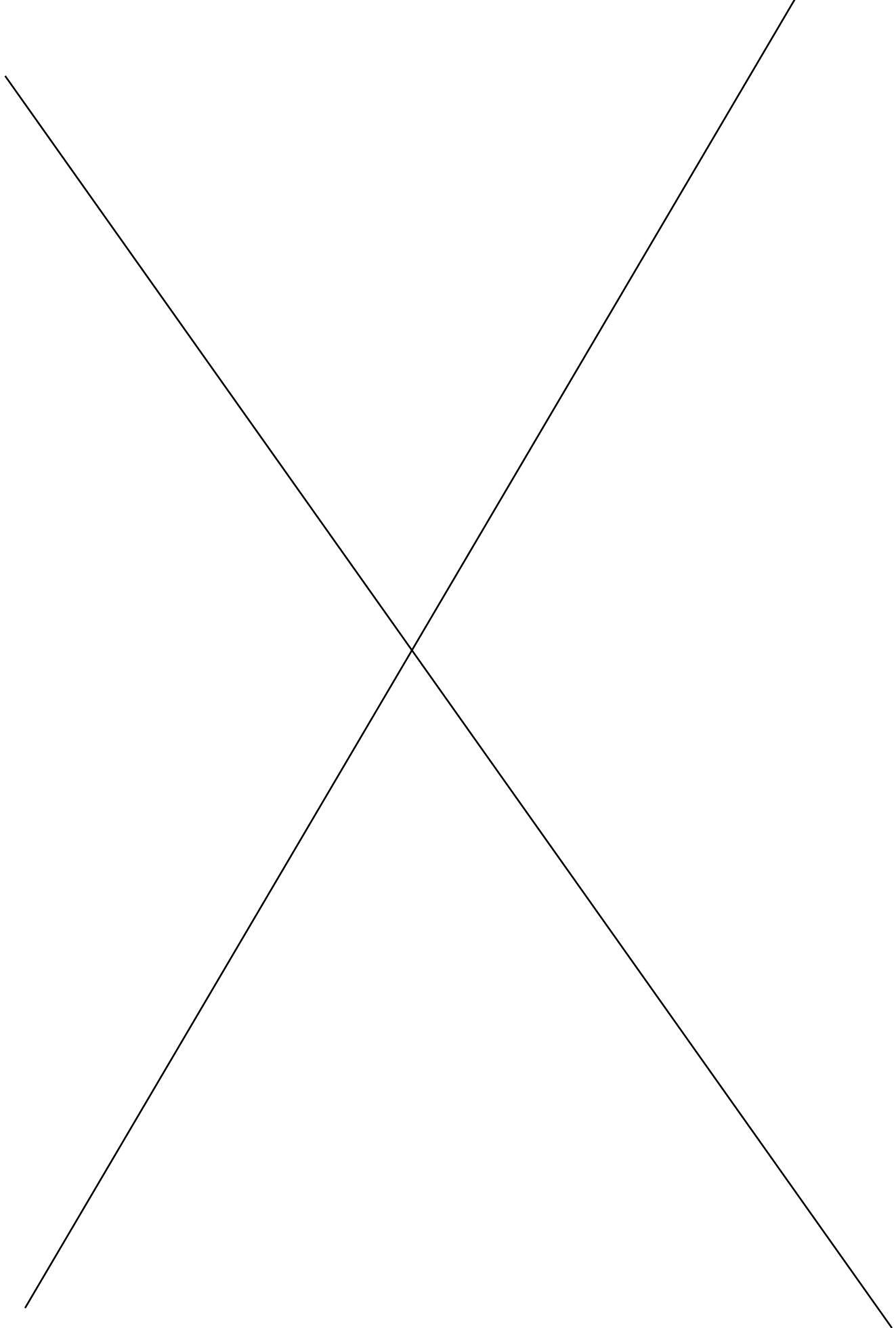

Fig. 1. ANSI/IEEE Standard C62.41 Combination Wave (open-circuit voltage, left, and short-circuit current, right).



in the real world. For example, "Zeus," the surge generator used at the authors' laboratory, includes plug-in modules for the ANSI/IEEE Standard C62.41 Ring Wave and Combination Wave.

Impulsive Surges Caused by Lightning

Based upon field experience and testing, Standard C62.41 proposes testing with a waveform that represents a surge resulting from lightning directly impinging upon or coupled into the power system (called a "combination wave"). Fig. 1, on page 62, shows the waveform of the open-circuit voltage and short-circuit current. Three characteristics specify the waveform: rise time (or front time, in the case of short-circuit current), duration, and amplitude.

During testing, the rise time and duration are held constant according to the ANSI/IEEE definition. On the other hand, varying the amplitude by ramping it up in 500V increments for each trial can cause equipment failure.

Applying Surges in the Laboratory

Whereas traditional surge testing is intended to reveal the withstand limits of equipment *without* deliberately damaging the equipment, the surge testing described here was

intended to cause damage so investigators can correlate observable and measurable effects with a known cause. Fig. 2 shows a simplified diagram of the setup used to surge test equipment. Zeus is composed of a surge generator to supply the surge voltage and current and a back filter/coupler to prevent surge current from feeding back into the power source and to couple the surge into the equipment under test. A digital signal analyzer monitors and records

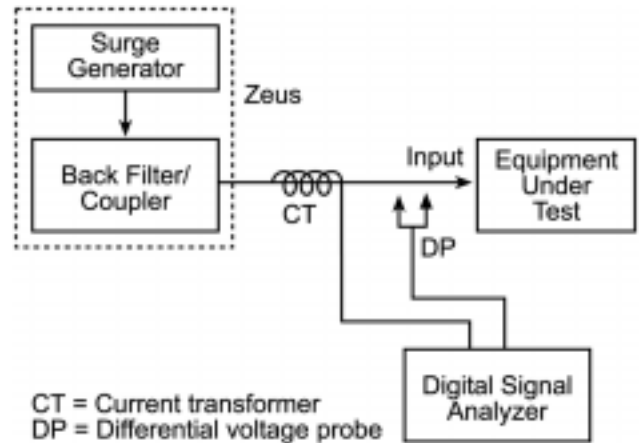

Fig. 2. Simplified diagram of test setup for surge testing equipment.

YUASA

Sealed Lead Acid UPS Batteries

No Minimum Order
Get Your Equipment Back On Line Fast Without The Hassle Of Having To Deal With Minimum Order Requirements

Highest Quality Available
Yuasa Brand Sealed Lead Acid UPS Batteries Are Used By More UPS System Manufacturers As Original Equipment

Exact Replacements
With Over 25 Yuasa UPS Battery Sizes To Choose From We Can Provide You With Quality Exact Replacements

Same Day Shipment
Fedco Electronics, Inc. Has The Entire Range Of Yuasa Brand UPS Batteries In Stock And Ready To Ship Today

"Visit Our Web Site For Full Product Listing"
www.fedcoelectronics.com

Call For Free Battery Catalog

Toll Free:
(800)
542-9761

FEDCO ELECTRONICS, INC.
P.O. Box 1403
Fond du Lac, WI 54935-1403

Fax:
(920)
922-6750

Power Quality Measurement & Recording

for power class
600V - 425KV
DC - 10MHz

VD30
5KV
60KV

VD60
15KV
110KV

VD120
38KV
200KV

VD120 OUTDOOR
5KV - 425KV
60KV - 1,450KV

For Power Quality analysis Ross Engineering Corporation has developed high voltage wideband Power Line Disturbance and Harmonic voltage transducers for observing or recording 600V to over 900KV PK, DC to 10MHz. These power class high voltage dividers are to provide a safe signal for most analyzers/recorders and oscilloscopes.

For more info visit our web site at:
www.rossengineeringcorp.com

ROSS ENGINEERING CORPORATION
540 Westchester Dr., Campbell, CA 95008
PHONE: (408) 377-4621 - FAX: (408) 377-5182
email: info@rossengineeringcorp.com

Circle 130 on Reader Service Card

freeproductinfo.net/pq

Circle 131 on Reader Service Card

freeproductinfo.net/pq

the voltage and current at the equipment power port.

Trial by Fire and Smoke

During the first stage of the project, about a dozen motor-and-control systems were tested. Each systems was composed of a motor, an adjustable-speed drive (ASD), and a programmable logic controller (PLC), as shown in **Fig. 3**.



Fig. 3. Test setup for surge testing a motor-and-control system.

The PLC was connected to 3-phase voltage via a step-down transformer, which supplied single-phase 120V power.

Fig. 4 and **Fig. 5**, on page 66, show examples of recorded waveforms during surge testing a motor-and-control system. **Fig. 4** shows the results of a trial where the current peaked at 1,200A. MOVs inside the ASD were able to clamp the voltage at about 600V. In this particular trial, the equipment survived the surge.

Fig. 5 tells a different story. During this trial, the current peaked at 1,400A. As shown in the voltage trace, the MOV clamped the voltage, but an unidentified component failed just after the peak current.

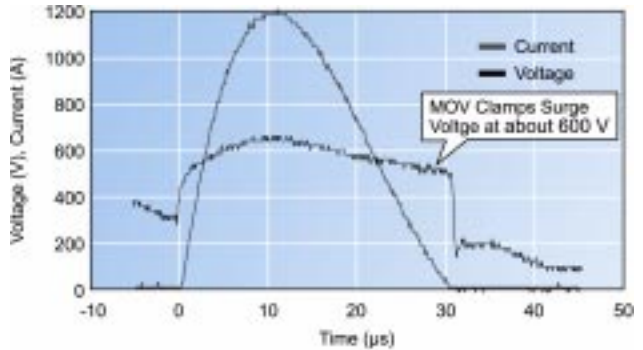

Fig. 4. Recorded waveforms during a single trial with a peak current of 1,200A.

TWELVE-PULSE

FIRING PACKAGE

...from Enerpro, known the world over for excellence in power electronics control

- ✓ Complete OEM Package
- ✓ For DC Converter and AC Controller Applications
- ✓ 12-Pulse Gating Eliminates 5th and 7th Harmonics
- ✓ Includes Power-On Reset, Soft-Start/Stop and Phase Loss Inhibit
- ✓ Single-Board (600 VAC, max) and Two-Board (1000 VAC) Versions

ENERPRO
 ENERPRO, Inc.
 5780 Thornwood Drive
 Goleta, CA 93117 (USA)
(800) 576-2114
 tel: (805) 683-2114
 fax: (805) 964-0798
 e-mail: info@enerpro-inc.com
www.enerpro-inc.com

Circle 132 on Reader Service Card

freeproductinfo.net/pq

Convert any 6-pulse drive to 12- or 18-pulse performance with the

MTE MATRIX™ HARMONIC FILTER

- Cost effective
- Compact size
- Highly reliable
- Cabinet or panel mount
- Guaranteed performance

Why spend more money for 12- or 18-pulse drives when you can get equal or better performance with standard 6-pulse drives using an MTE Matrix™ Harmonic Filter! And, the Matrix Harmonic Filter gives you guaranteed performance.

MTE CORPORATION
 Guaranteed Results!

www.mtecorp.com
 Phone: 262-253-8200
 Fax: 262-253-8222
 W147 N9525 Held Dr.,
 Menomonee Falls, WI 53052-9013

Circle 133 on Reader Service Card

freeproductinfo.net/pq

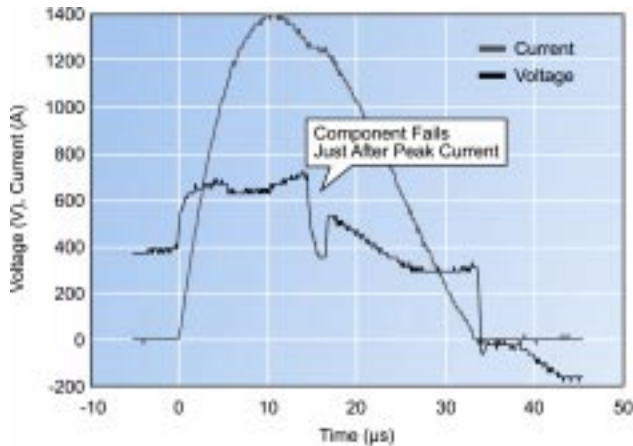

Fig. 5. Recorded waveforms during a single trial with a peak current of 1,400A.

Fig. 6 shows one of the ASDs that failed during surge testing. The catastrophic failure of a filter capacitor resulted in an explosion followed by smoke billowing from the ASD vents. The failure of MOVs and filter capacitors is *not* an unexpected consequence of a strong surge applied to equipment with these components in the front end. Note the soot remaining on the components (near the bottom left) result-



Fig. 6. Damage caused by a surge.

ing from the explosion of the filter capacitor. Also note the burned circuit trace resulting from excessive current—revealing evidence about the mode of failure.

Failure Analysis

The next stage of the project—to be conducted later this year—is the meticulous analyzing of each tested ASD and PLC to determine modes of failure. This analysis will go beyond obvious damage detected during visual inspection. To construct a comprehensive catalog of failed components and equipment parts, it is necessary to restore each piece of equipment to working condition.

By troubleshooting and repairing surge-damaged equipment, it is possible to develop a knowledge base of surge-related failure for classes of equipment: industrial equipment, such as ASDs and PLCs; commercial equipment, such as video cameras and card readers; and residential appliances, such as security systems and entertainment systems.

Understanding common failure modes among classes of equipment will enable manufacturers to improve the surge-withstand capabilities of their equipment, resulting in fewer claims of damaged equipment for utilities and insurance companies, as well as reduced inconvenience for end users.

Next Month

In next month's article, the authors will discuss surge testing the communication port of equipment and reveal some preliminary findings of their investigation. **PQ**

Brad Connatser is the publications manager at EPRI PEAC Corp. in Knoxville, Tenn. You can reach him at bconnatser@epri-peac.com. Doni Nastasi is a power quality engineer at EPRI PEAC Corp. You can reach him at dnastasi@epri-peac.com. Kermit Phipps is a power quality and EMC specialist at EPRI PEAC Corp. You can reach him at khipps@epri-peac.com.

Ground Difficult Sites



A **conductive cement groundbed** is the engineer's solution to your lightning protection problem. With forethought and measurement, you can specify exactly the conductive cement groundbed you need for appropriate, permanent, reasonably priced protection.

• **Installation costs are much lower** than for chemically charged grounding systems.



- The **total cost** can be a fraction of that of a chemical system.
- **Dramatically lowers surge impedance** over both conventional and chemically charged grounding systems.
- **Environmentally safe.**
- **Significantly reduces electrode corrosion.**
- **Easy to install.**
- **Maintenance-free and permanent.**



electric motion company, inc.
860/379-8515
 110 Groppo Drive
 Winchester Business Park
 Winsted CT 06098
 fax 860/379-7835
www.electricsmotioncompany.com

Call us for sample quantities, technical backup, or volumes. Ask for product # EM-M5C. We have it.

Circle 134 on Reader Service Card

freeproductinfo.net/pq